

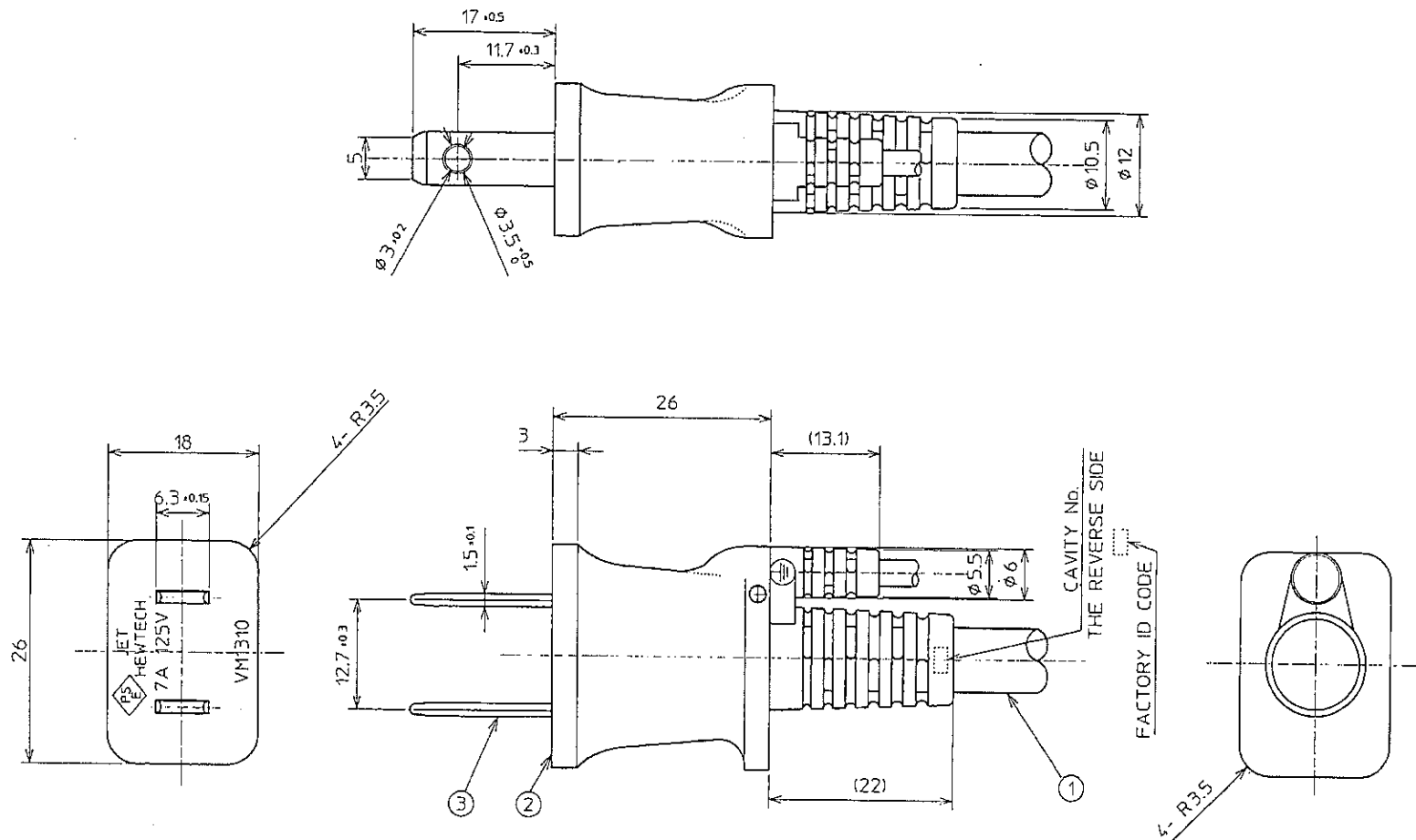

IT	NAME	MATERIAL	REMARK
1	CORD	HVCTF 3x0.75mm ²	
2	BODY	PVC	
3	CONTACT BLADE	C2680RC-1/2H MBN	(A-323 A-354



△ X				 MIRAKAWA HEWTECH CORP.	TOLERANCE	ANGLE	SCALE	UNIT	NAME
△ X					DIMENSION	DR	2 : 1	mm	2P-PLUG
△ X					L ± 0.3	K. Morishita	DATE	Feb. 25 '03	PART NO.
△ X						I. Igarashi	DATE	Feb. 25. 03	VM13100-C0
LET	REVISION	DATE	SIGN			APP.	DATE	Feb. 25. 03	MC1209CA

IT	NAME	MATERIAL	REMARK
1	CORD	HVCTF,HVCTFS 3X0.75mm ²	
2	CONNECTOR BODY	PVC	
3	CONTACT SLEEVE	C-5191R-H	B-169
4	INNER BASE	POLYACETAL	C-210

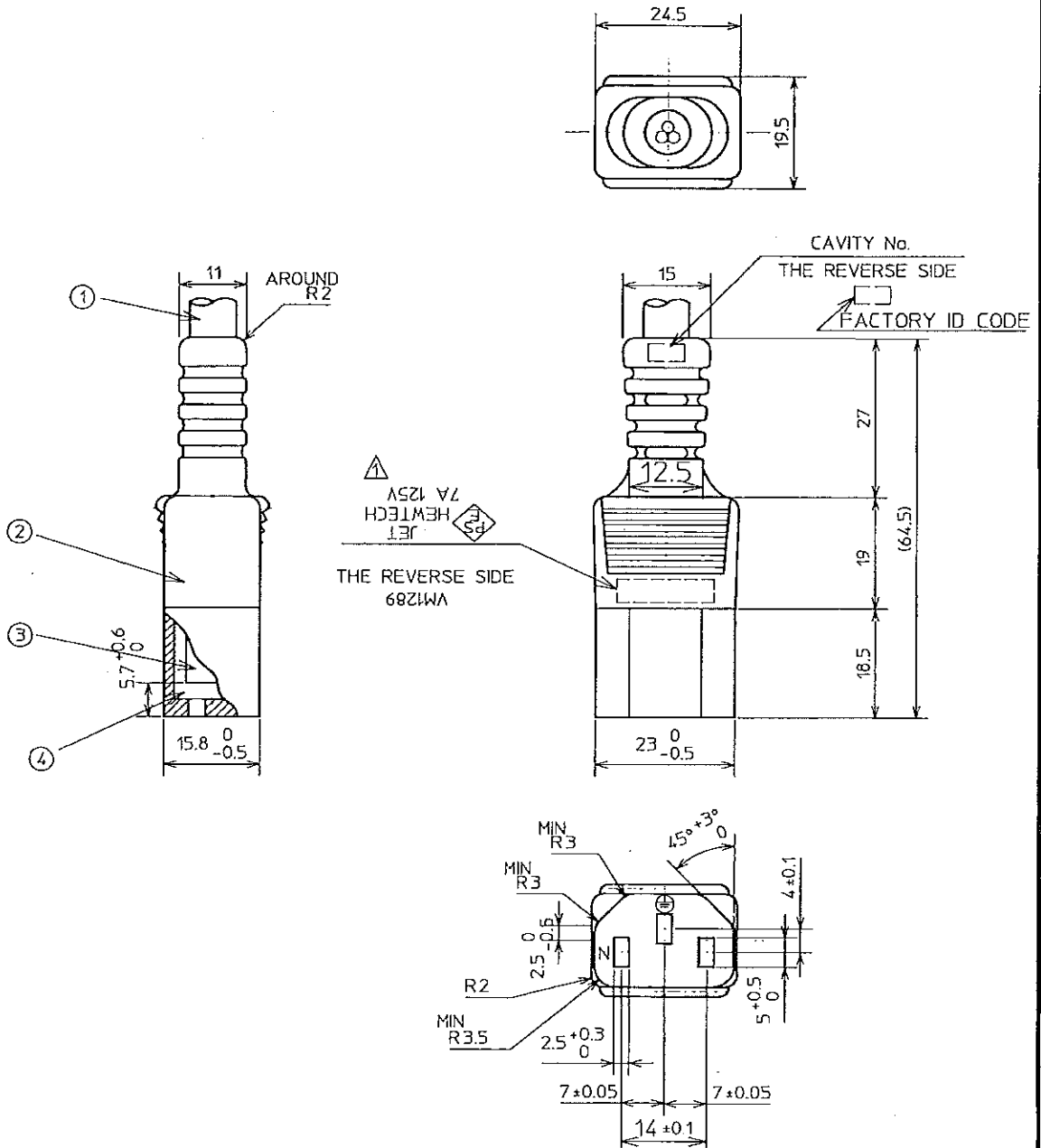

△X				DR. K.Morishita	DATE Feb.18'03
△X				CH. I.Igarashi	DATE Feb.18'03
△X	1 変更	Feb.23'06	K.Morishita	APP Y.Matsunaga	DATE Feb.18'03
LET	REVISION	DATE	SIGN	NAME	3P-CONNECTOR
 HIRAKAWA HEWTECH CORP.		TOLERANCE		ANGLE	PART NO. VM12890-G0
		DIMENSION	TOL.	SCALE	
		L≤63	±0.5	UNIT mm	
				DRAWING NO.	MC1202CB